

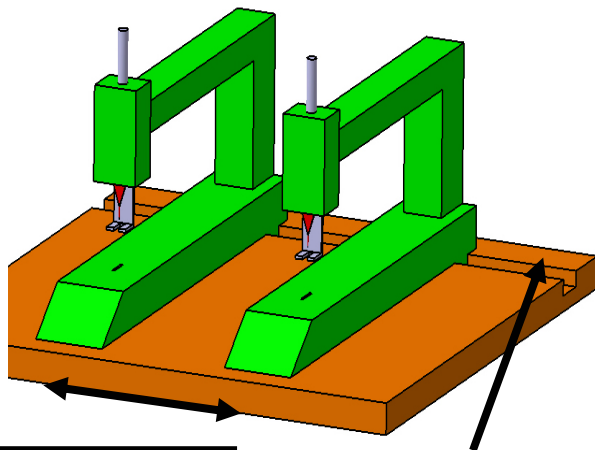

Machine for attaching cardboard or plastic rider header cards to **CAR MATS BY SPECIAL HIGHLY RESISTANT PLASTIC PINS** for hanging display in the retail trade

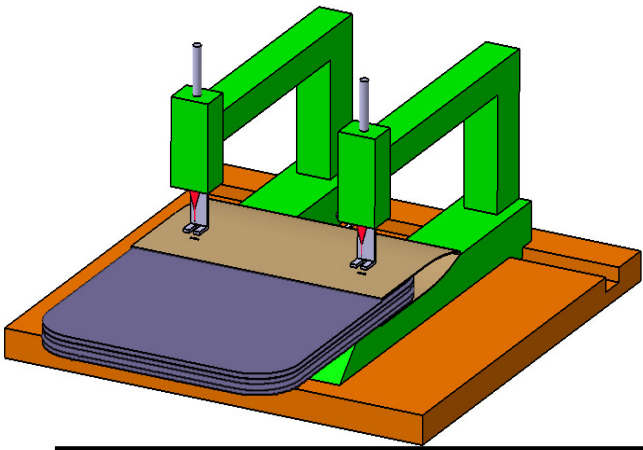

Version 2 pins

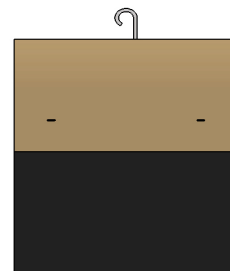

Version 3 pins

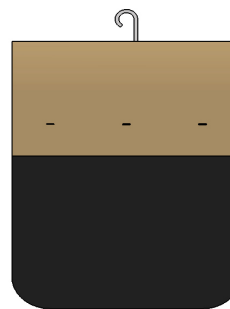

IMPORTANT ORIGINAL FEATURES

slide to settle fastening heads

This new process uses plastic pins of special quality and design for replacing metal staples. The plastic pins are fastened thanks to a micro-perforation device that facilitates the pins insertion in order to avoid any damage to heavy and rigid products such as CAR MATS or SIMILAR PRODUCTS.

QUALITY

Excellent display.
The fastening pins are easily removed by customers.

FLEXIBILITY

Setting the spacing between fastening heads is quickly achieved by the operator with no tools.
Possibility to get machines with 1,2 or 3 heads.

PRODUCTIVITY

High-productivity thanks to quick fastening cycle and to the design of the workstation which may be adapted on request of the customer for a precise organization.

APPLICATIONS

Car mats or similar products.

Customized adaptations available upon request.

- Plastic pins fastened in a line.
- Plastic pins fastened in various places.
- Automatic header card dispenser.
- Automated lines etc.

For any information :
 Advising Dept.
 Mr Jean-Philippe VIGOUROUX
 TEL : +33 3 25 76 05 61
 E-mail : tecma@tecma.fr
 Site web : www.tecma.fr